

Transducers

Dual mode transducers, capable of separating horizontal and vertical polarized waves, are readily available in most waveguide sizes. MDL's investment castings provide rigid, compact construction to insure precise mechanical configuration and excellent electrical performance. These designs feature low VSWR and insertion loss, high isolation and power handling capabilities.

Square output openings are standard except where noted. Circular outputs, other than those shown in the data below, and special flanges can be supplied upon request.

W/G Size	Frequency GHz	Style	Model Number	*VSWR Maximum		Mechanical Dimensions†			Output Dimensions		
				H Arm	E Arm	H	E	L	A	B	
Dual Mode Transducers											
WR22	35.5-37.5	1	22TR12	1.25	1.25	0.35	0.35	0.55	0.220	0.252	+0.03 -0.00
WR28	34.0-36.0	1	28TR12	1.20	1.20	0.50	0.43	0.81	0.204	0.286	+0.02 -0.00
WR42	19.5-23.0	1	42TR12	1.30	1.20	0.75	0.60	1.50	0.340	0.425	+0.03 -0.00
WR51	16.0-17.0	1	51TR12	1.15	1.15	1.00	0.79	1.50	0.454	0.536	+0.03 -0.00
	15.65-17.1	2	51TR22	1.15	1.20	0.75	1.20	1.32	0.600	0.500	±0.05
WR62	13.0-14.0	1	62TR22	1.15	1.15	1.10	0.95	1.80	0.562	0.645	+0.03 -0.00
	14.0-15.0	1	62TR32	1.12	1.12	1.10	0.85	1.80	0.519	0.599	+0.03 -0.00
	15.0-17.0	1	62TR12	1.15	1.15	1.10	0.95	1.80	0.454	0.536	+0.03 -0.00
WR75	10.8-11.5	1	75TR12	1.15	1.10	1.28	1.15	1.98	0.678	0.780	+0.03 -0.00
WR90	8.5-9.6	1	90TR12	1.10	1.10	1.75	1.35	2.50	0.800	0.905	+0.03 -0.00
	9.2-10.2	1	90TR22	1.25	1.25	1.75	1.35	2.50	0.800	0.905	+0.03 -0.00
WR112	7.0-8.0	1	112TR12	1.15	1.15	2.04	1.34	3.04	0.995	1.128	+0.04 -0.00
	7.0-8.0	2	112TR22	1.15	1.15	2.04	1.34	3.04	1.288	1.160	±0.05
	7.3-8.3	1	112TR32	1.55	1.45	2.04	1.34	3.04	0.995	1.128	+0.04 -0.00
WR137	5.4-5.9	1	137TR12	1.10	1.10	2.18	1.13	3.68	1.372	1.503	+0.05 -0.00
	5.4-5.9	1	137TR22	1.10	1.10	2.18	1.58	3.68	1.372	1.503	+0.05 -0.00
WR284	2.6-3.2	1	284TR32	1.50	1.15	4.16	3.30	6.63	2.525	2.690	+0.08 -0.00
	2.65-3.1	1	284TR12	1.20	1.15	4.16	3.30	6.63	2.525	2.690	+0.08 -0.00
	2.7-3.1	1	284TR22	1.15	1.12	4.16	3.30	6.63	2.525	2.690	+0.08 -0.00

Notes: Minimum isolation 40 db
 † Dimensional tolerances
 WR22 through WR137±.015
 WR284±.020

MITRE H PLANE TEES

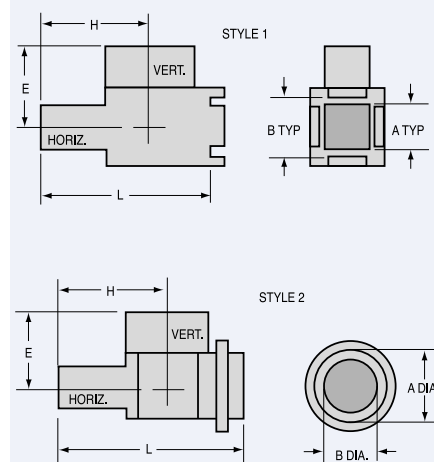

Transducers

TRANSDUCERS

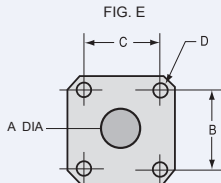
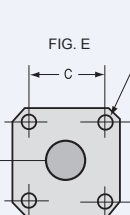
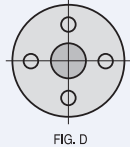
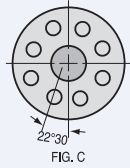
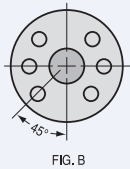
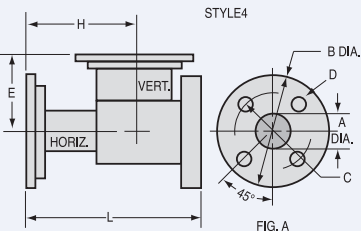
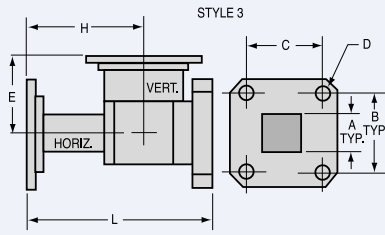

W/G Size	Frequency GHz	Style	Model Number	*VSWR Maximum		Mechanical Dimensions†						Flange pattern			
				H Arm	E Arm	H	E	L	A	B	C		D		
WR28	34.0-36.0	3	28TR16	1.20	1.20	0.50	0.54	0.81	.204	.500	.530	.116	-		
	34.0-36.0	4	28TR26	1.20	1.20	0.50	0.54	0.997	.238	.500	.530	THD	FIG. E		
WR42	19.5-23.0	4	42TR36	1.30	1.20	0.91	0.76	1.520	.400	1.135	.670	.116	FIG. A		
WR51	16.0-17.0	3	51TR16	1.15	1.15	1.00	1.10	1.50	.454	.956	.994	.144	-		
	15.65-17.1	4	51TR26	1.15	1.20	1.00	1.10	1.57	.500	1.350	.925	.144	FIG. A		
WR62	15.0-17.0	3	62TR16	1.15	1.15	1.10	1.18	1.80	.454	.956	.944	.144	-		
	13.0-14.0	3	62TR26	1.15	1.15	1.17	1.00	1.87	.562	.956	.994	.144	-		
	14.0-15.0	3	62TR36	1.12	1.12	1.10	0.95	1.68	.519	.956	.994	.144	-		
	13.75-15.25	4	62TR46	1.30	1.20	1.15	1.18	1.855	.590	1.300	1.000	6-32 THD	FIG. D		
	15.0-17.0	4	62TR56	1.20	1.20	1.10	1.18	1.80	.590	1.500	1.070	.144	FIG. A		
WR75	10.8-11.5	3	75TR16	1.15	1.10	1.28	1.15	1.98	.678	1.10	1.10	.144	-		
WR90	8.5-9.6	3	90TR36	1.10	1.10	1.75	1.35	2.50	.800	1.280	1.220	.169	-		
	9.2-10.2	3	90TR46	1.25	1.25	1.75	1.35	2.50	.800	1.280	1.220	.169	-		
	8.5-9.6	4	90TR56	1.25	1.25	1.75	1.35	2.500	.930	1.600	1.360	8-32 THD	FIG. D		
WR112	7.0-8.0	3	112TR16	1.15	1.15	2.04	1.34	3.04	.995	1.474	1.352	.169	-		
	7.2-7.8	4	112TR26	1.15	1.15	2.27	1.50	2.98	1.160	2.34	1.75	.169	FIG. B		
	7.3-8.3	3	112TR36	1.55	1.45	2.04	1.34	3.04	.995	1.474	1.352	.169	-		
	7.3-8.3	4	112TR46	1.55	1.45	2.27	1.50	2.98	1.160	2.34	1.76	.169	FIG. B		
WR137	5.4-5.9	3	137TR16	1.10	1.10	2.33	1.58	3.83	1.372	2.250	2.125	10.32 THD	-		
WR284	2.65-3.1	3	284TR16	1.20	1.15	4.16	3.30	6.63	2.525	8 HOLE FLANGE 284FT22		-	.257	-	
	2.7-3.1	3	284TR26	1.15	1.12	4.16	3.30	6.63	2.525			-	.257	-	
	2.6-3.2	3	284TR36	1.50	1.15	4.16	3.30	6.63	2.525			-	.257	-	
	2.7-3.1	4	284TR46	1.20	1.17	4.16	3.30	7.75	2.940	6.50			-	.257	FIG. C
	2.7-2.9	4	284TR56	1.20	1.20	4.16	3.30	7.75	2.940	6.50			-	.257	FIG. C

Notes: Minimum isolation 40dB

*Dimensional tolerances WR22 through WR137±.015
WR284±.020