

# Section 8

## Pads & Fixed Attenuators

---



### Introduction

MDL offers compact attenuator pads having excellent electrical characteristics. They are particularly useful where space is a critical factor.

These units, in EIA waveguide sizes WR28 through WR90, span the frequency range from 8.5-37.0 GHz with attenuation from 10 to 50 dB. As shown, these attenuator pads are available as elements which can be inserted into a waveguide, or they can be built into a length of waveguide with choke or cover flanges on either end.

# Ordering Information\*

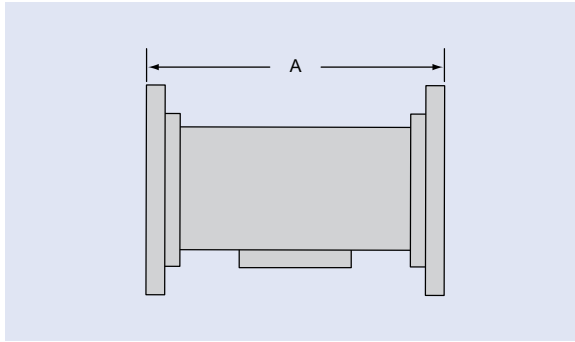

Example: 62ASF16-1-E-20-10P

MODEL NUMBER

FLANGE

MATERIAL

ATTENUATION

PRESSURE

## 62ASF16 - 1 - E - 20 - 10P

### Flange Termination - 2 Flanges

Flange	Port 1	Port 2
1	Cover	Cover
2	Cover	Choke
3	Choke	Cover
4	Choke	Choke

When using choke flanges, add the thickness of the flanges to the overall dimensions. Check with factory for final dimensions

### Material and Finish

Code	Material	Finish
C	Aluminum Alloy	Chromated
D	Copper Alloy	Silver Plated
E	Aluminum Alloy	Chromated and Painted Blue
F	Copper Alloy	Silver Plated and Painted Blue

### Attenuation

Number indicates fixed attenuation setting in dB

### Pressurized for 20PSIG.

Number indicates desired pressure

For non-pressurized, omit numerals and "P".

# Pads & Fixed Attenuators

## Sidewall Fixed Attenuators

MDL series of sidewall fixed attenuators have the size and reliability of the sidewall variable attenuators. Modifications of these models are available to meet special customer requirements.

W/G SIZE	FREQ. RANGE (GHz)	MDL MODEL NUMBER	VSWR MAX. (0-15dB)	ATTENUATION RANGE (dB MIN.)	LENGTH (INCHES) "A" $\pm 0.20$
WR62	12.4-18.0	62ASF16	1.15	1.0-20.0	2.00
WR75	10.0-15.0	75ASF16	1.15	1.0-20.0	2.25
WR90	8.2-12.4	90ASF16	1.15	1.0-20.0	2.50
WR102	7.0-11.0	102ASF16	1.15	1.0-20.0	3.00
WR112	7.05-10.0	112ASF16	1.15	1.0-20.0	3.50
WR137	5.85-8.20	137ASF16	1.15	1.0-20.0	4.00
WR187	3.95-5.85	187ASF16	1.15	1.0-20.0	5.00

FIXED ATTENUATORS

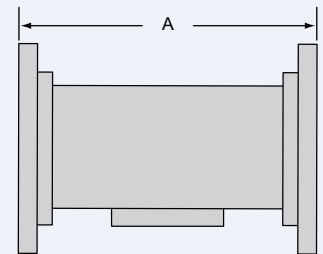

# Pads

## Pad Element

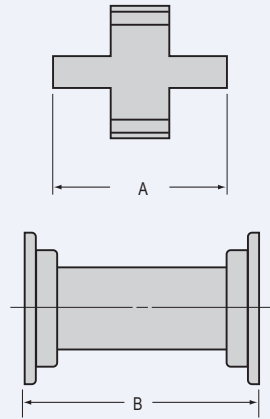

W/G SIZE	FREQ. RANGE (GHz)	MDL MODEL NUMBER	ATTENUATION dB (NOMINAL)	SENSITIVITY dB (MAX.)	VSWR (MAX.)	PAD ELEMENT A (MAX.)
WR28	31.0-37.0	28AF12	10±1	±0.50	1.20	0.50
	31.0-37.0	28AF22	20±1	±1.00	1.25	0.90
	31.0-37.0	28AF32	30±1	±1.00	1.25	1.40
WR62	15.5-17.5	62AF12	20±1	±0.50	1.15	0.60
	15.5-17.5	62AF22	30±1	±0.50	1.15	0.75
	15.5-17.5	62AF32	40±1	±1.00	1.15	0.95
WR75	10.0-15.0	75AF12	10±1	±1.00	1.50	0.75
WR90	8.5-10.5	90AF12	20±1	±0.50	1.20	1.05
	8.5-10.5	90AF22	30±1	±0.50	1.20	1.40
	8.5-10.5	90AF32	40±1	±0.50	1.20	1.75
	8.5-10.5	90AF42	50±1	±1.00	1.20	2.05

## Attenuator with Pad in Waveguide

W/G SIZE	FREQ. RANGE (GHz)	MDL MODEL NUMBER	ATTENUATION dB (NOMINAL)	SENSITIVITY dB (MAX.)	VSWR (MAX.)	ATTENUATOR PAD "B" (+0.20)
WR28	31.0-37.0	28AF16	10±1	±0.50	1.20	0.70
	31.0-37.0	28AF26	20±1	±1.00	1.25	1.11
	31.0-37.0	28AF36	30±1	±1.00	1.25	1.60
WR62	15.5-17.5	62AF16	20±1	±0.50	1.15	1.00
	15.5-17.5	62AF26	30±1	±0.50	1.15	1.15
	15.5-17.5	62AF36	40±1	±1.00	1.15	1.35
WR75	10.0-15.0	75AF16	10±1	±1.00	1.50	1.15
WR90	8.5-10.5	90AF16	20±1	±0.50	1.20	1.45
	8.5-10.5	90AF26	30±1	±0.50	1.20	1.80
	8.5-10.5	90AF36	40±1	±0.50	1.20	2.15
	8.5-10.5	90AF46	50±1	±1.00	1.20	2.45