

Section 9

Phase Shifters



Introduction

MDL hybrid phase shifters are generally used for high peak or average power experimental applications. They provide 360° of phase variation and are precisely adjustable and resettable.

MDL low-power dielectric phase shifters are available from WR28 through WR137 waveguide sizes, and are ideal as phase trimmers in monopulse applications. Their space-saving design also permits assembly of more variable phase shifters.

Phase Shifters

Hybrid Phase Shifters

The phase shift is approximately linear with dial rotation, but is not linear with frequency. As a result, calibration accuracy is limited to the particular frequency of the calibration. They can also be used in low power set-ups where ease of reset ability and compact physical configuration are desired.

These units maybe readily modified to meet customers' particular requirements. MDL hybrid phase shifters can be supplied pressure tight as well as with water cooling tubes for high average power.

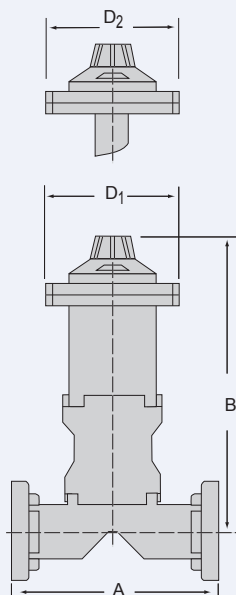

W/G SIZE	FREQ. RANGE (GHz)	MDL MODEL NUMBER	DIMENSIONS			
			A	B	C	D (REF.)

Hybrid Phase Shifters

WR28	34.0-36.0	28PS16	1.93	4.90	1.39	1.27
WR42	19.0-21.0	42PS26	2.07	5.24	1.39	0.87
WR62	15.5-17.0	62PS46	2.62	5.40	1.77	1.33
	12.4-14.0	62PS56	2.62	5.36	1.77	1.33
	14.2-15.2	62PS36	2.62	5.15	1.77	1.33
WR90	8.5-9.6	90PS26	2.98	7.42	2.58	1.62
WR112	8.5-9.6	112PS66	4.27	8.25	3.22	1.37
	7.5-8.5	112PS76	4.35	8.44	3.22	1.37
WR137	5.4-5.9	137PS26	4.66	10.62	3.80	1.61
	5.8-6.5	137PS46	4.66	10.62	3.80	1.61
	6.1-6.9	137PS36	4.66	10.62	3.80	1.61
WR187	5.4-5.9	187PS46	5.75	11.50	5.03	2.03
	4.4-5.0	187PS56	5.79	13.91	5.03	2.03
WR284	2.85-3.15	284PS46	10.25	20.06	7.22	2.72
	2.66-2.99	284PS56	10.25	21.15	7.22	2.72

- Notes:**
- Tolerances:**
 ± .020 WR28, WR42, WR62, WR90, WR112
 ± .030 WR137
 ± .040 WR187, WR284
 - Attenuation:** (port 1 to port 3, and port 1 to port 4): 28db minimum
 - Material:** Aluminum alloy standard, copper alloy available on special request.
 - Finish:** Aluminum models are chromated.
 - * Flanges:** Cover flanges are supplied. Other types of flanges are available upon request.
 - Drive:** WR28 & WR42 have micrometer drives. WR62 thru WR284 have dial pot drives as shown.
 - Electrical Specifications-**
 Phase Shift: 360° min
 VSWR: 1.20:1 max. (except MDL models 28PS16-1 & 42PS26-1 which are 1.25:1 max.)
 Insertion Loss: 0.25 dB max. (except MDL models 62PS36-1, 62PS46-1, 62PS56-1, 42PS26-1 & 28PS16-1 which are 0.30 dB max.)
 Peak Power: Approx. 18 kilowatts in WR28 to approx. 2.0 megawatts in WR284 at sea level. Higher powers can be handled with additional air pressure.

Phase Shifters

Low Loss Dielectric Phase Shifters

W/G SIZE	FREQ. RANGE	MODEL NUMBER	DIMENSIONS (INCHES) (TOL *± .020)			FIG.	VSWR (MAX.)	VARIABLE PHASE SHIFT (DEGREES) 0 TO MIN.	INSERTION LOSS (dB MAX.)
			A	B	C				
WR28	33.0-37.0	28PE16	1.20	0.98	0.14	3	1.20	90	0.25
WR42	22.5-24.0	42PE16	1.30	1.02	0.14	3	1.20	90	0.25
WR51	15.5-17.0	51PE16	1.87	1.20	0.16	1	1.15	90	0.30
	15.5-17.0	51PE26	2.85	1.20	0.16	1	1.15	180	0.30
WR62	15.5-17.0	62PE26	2.20	1.20	0.16	1	1.20	90	0.30
	15.5-17.0	62EP36	3.20	1.20	0.16	1	1.20	180	0.30
	14.5-15.5	62EP56	3.20	1.20	0.16	1	1.20	180	0.20
	13.5-15.2	62EP66	3.00	1.23	0.16	1	1.25	180	0.30
WR75	10.0-11.0	75PE16	3.00	1.55	0.18	1	1.20	180	0.30
WR90	8.5-9.6	90PE26	3.00	1.56	0.16	3	1.15	180	0.10
	8.5-9.6	90PE86	3.00	1.54	0.16	3	1.15	180	0.10
	9.6-10.2	90PE76	2.99	1.56	0.16	3	1.20	180	0.25
WR112	7.4-8.5	112PE46	6.00	1.88	0.16	3	1.25	180	0.25
	8.5-9.6	112PE56	7.00	1.73	0.17	3	1.20	180	0.25
WR137	5.4-5.9	137PE16	8.00	3.32	-	2	1.15	180	0.10

Notes:

1. Material: Aluminum alloy standard, copper available on request.
2. Flanges: Cover flanges.
3. Finish: Aluminum models chromated.

FIGURE 1

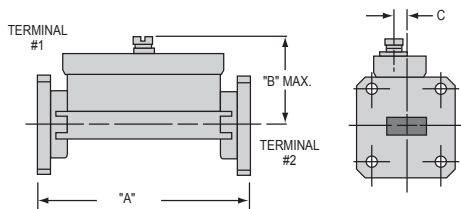

FIGURE 2

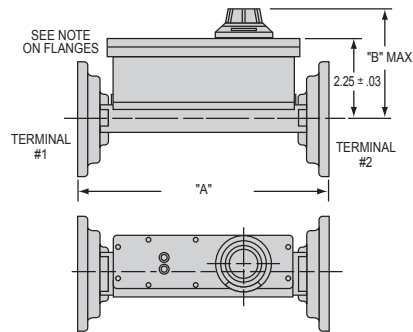

FIGURE 3

